

MODULAR CONCEPT

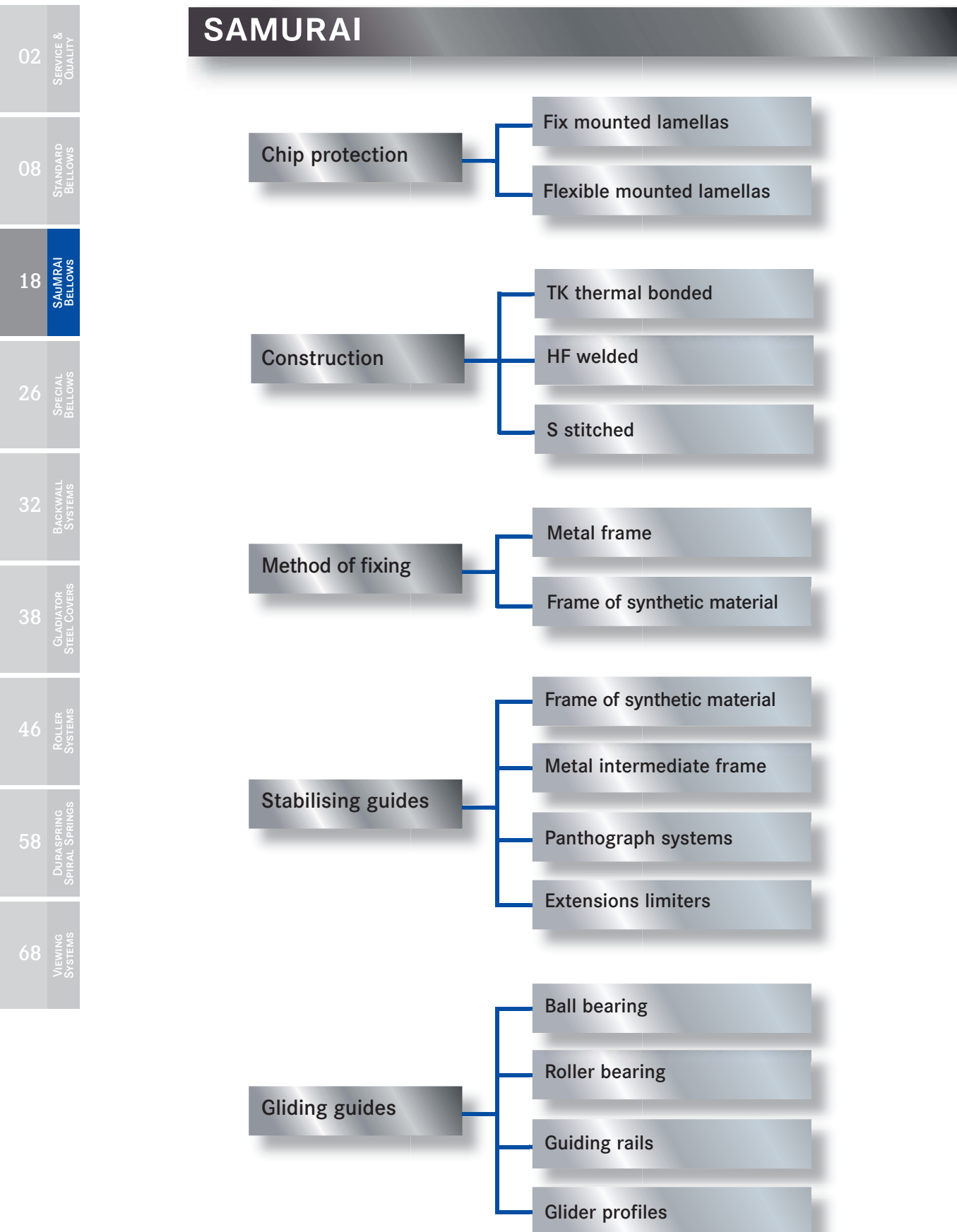

SAMURAI BELLOWS

SAMURAI Bellows are an advancement of the ELASTIC Bellows product line. Characteristic for this type of bellows are their lamellas.

The lamellas are fixed at the upper edge of the bellows, which also reinforces them. They provide excellent protection against fast, very hot and sharp chips.



SAMURAI Bellow

SAMURAI Bellows are ideal for HSC applications. Solutions for machining centres with speeds greater than 100 m/min and accelerations greater than 2 g have been successful realized.

Type of bellow	heavy swarf impact	X/Y axis	Z axis	less space
ELASTIC		■		■
FASTAF	■	■	■	
FASTAM			■	■
FASTAC	■			
Vector C ²	■	■		
FASTLAP			■	■

Design

Similar the ELASTIC range of products, all materials, shapes, processing methods, and measurements for the SAMURAI Bellows can be combined in any variation. Also a PVC frame is built into each fold of this bellow for assured stability.

Lamellas

The position of each lamella can be individually chosen. The lamellas can be fixed to the front of the bellows, each side, or in any combination.

In addition, our in house production of lamellas means we can provide them in nearly all forms, such as inclined or roof types. Stainless steel is used for the material.



Excellent closing and sealing on the top side

Usually the basic lamella type is flat with its end formed into a wiper profile, for excellent contact and sealing on the top side of the SAMURAI Bellow.

There is a high contact pressure across the whole lamella area. With their efficient wiper edge the lamellas prevent debris from entering the interior.

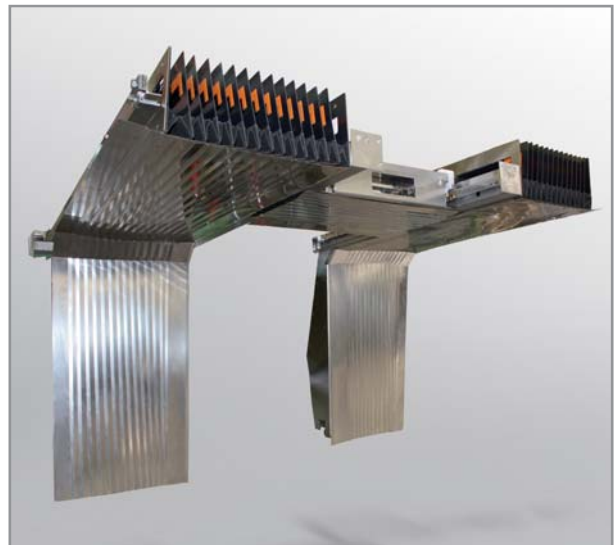

Example SAMURAI Bellows type Vector C²; a ready to install solution including interlocking system for loading through the roof. Combination with optional mechatronics system »CoverShutter« possible.

SERVICE & QUALITY 02

STANDARD BELLOWS 08

SAMURAI BELLOWS 19

SPECIAL BELLOWS 26

BACKWALL SYSTEMS 32

GLADIATOR STEEL COVERS 38

ROLLER SYSTEMS 46

DURASPRING SPIRAL SPRINGS 58

VIEWING SYSTEMS 68

SAMURAI BELLOWS

02

SERVICE & QUALITY

08

STANDARD BELLOWS

20

SAMURAI BELLOWS



Application of lamella bellows

When in use the lamellas develop a regular formation of stripes on their surfaces. This is normal and caused by their edges and has no effect on their functionality or service life.

The lamellas are corrosion and acid proof, but not accessible.

SAMURAI Bellows are available in three basic types.

These main types are based on how the lamellas are fixed:

- FASTAF - fixed lamellas
- FASTAC - fixed telescopic lamellas
- FASTAM - flexible lamellas
- FASTAF Vector C² - special type for multi axis protection

26

SPECIAL BELLOWS

32

BACKWALL SYSTEMS

38

GLADIATOR STEEL COVERS

46

ROLLER SYSTEMS

58

DURASPRING SPIRAL SPRINGS

68

VIEWING SYSTEMS

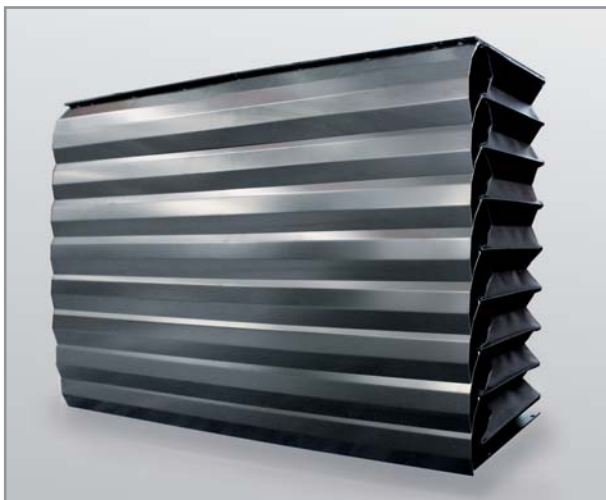

SAMURAI FASTAM

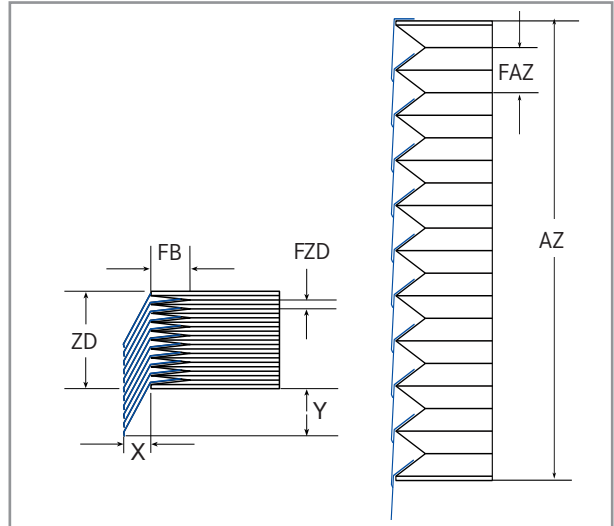

Drawing of FASTAF/FASTAC

Legend

FB	Width of fold
FZD	Compression per fold
2FZD	Compression per two folds
FAZ	Extension per fold
2FAZ	One sheet of lamella protects two folds
FHub	Stroke per fold
AZ	Maximum extension
ZD	Minimum compression
X	Horizontal space required for the lamellas
Y	Vertical space required for the lamellas

FB	FAZ	FZD	X	Y
17,5	20	5	20	40
20	25	5	20	45
25	32	5	25	50
30	40	5	25	65
35	45	5	30	75
40	60	5	35	80
45	65	5	35 - 40	85
50	75	5	45 - 50	95

FASTAF/FASTAC

FB	2FAZ	2FZD	Y
15	40	5-10	65
17,5	45	5-10	75
20	55	5-10	75
25	70	5-10	90
30	85	5-10	105
35	100	5-10	120
40	125	5-10	155

FASTAF 2-folds (one sheet of lamella protects two folds)

SAMURAI BELLOWS

FASTAF

FASTAF types are SAMURAI Bellows with fixed lamellas. Owing to this design the lamellas overlap. The lamellas are hinged or clipped. When damaged they can be replaced.



SAMURAI FASTAF, demonstration of »overlapping«

FASTAC

FASTAC types are SAMURAI Bellows with fixed telescopic lamellas (boxes).

The lamellas cover the front and also the side parts of the bellows, forming an enclosed surface. These »closed« FASTAC lamella bellows are primarily used in a vertical operating position as an alternative to telescopic steel covers.

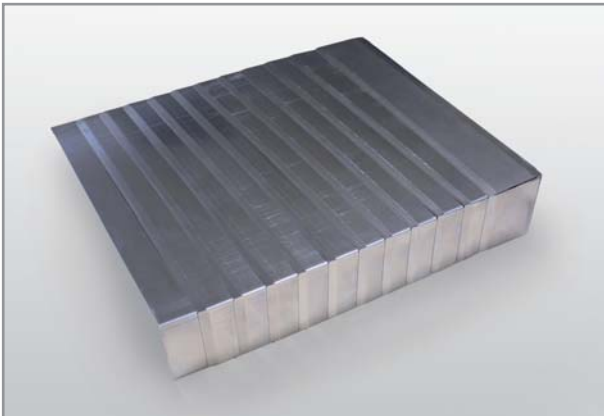

SAMURAI FASTAC

FASTAM

SAMURAI Bellows of the FASTAM type are equipped with flexible fixed lamellas, so lamella projection must be taken into consideration. The lamellas "stack" when the cover is compressed.

The lamellas are hinged or clipped. When damaged they can be replaced.



SAMURAI FASTAM, flexible fixed lamellas

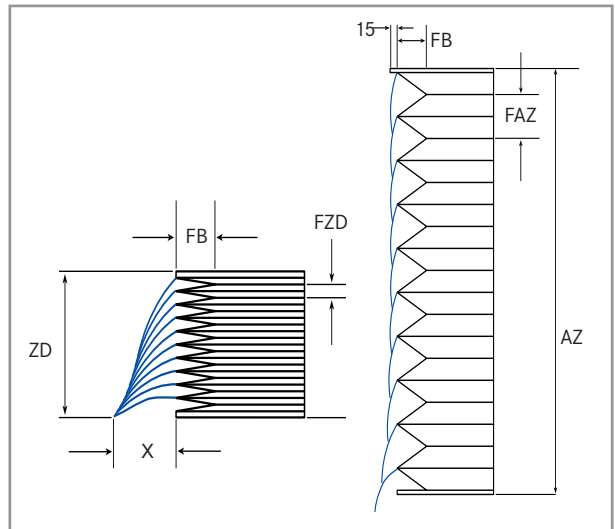

Drawing of FASTAM

Legend

FB	Width of fold
FZD	Compression per fold
FAZ	Extension per fold
ZD	Minimum compression
AZ	Maximum extension
X	Horizontal space required for the lamellas

FB	FAZ	FZD	X
17,5	22	5	50
20	30	5	50
25	38	5	65
30	48	5	75
35	55	5	85
40	65	5	85
45	75	5	100
50	85	5	110

SERVICE & QUALITY 02

STANDARD BELLOWS 08

SAMURAI BELLOWS 21

SPECIAL BELLOWS 26

BACKWALL SYSTEMS 32

GLADIATOR STEEL COVERS 38

ROLLER SYSTEMS 46

DURASPRING SPIRAL SPRINGS 58

VIEWING SYSTEMS 68

SAMURAI BELLOWS

VECTOR C² type

The FASTAF type VECTOR C² is a special type for machining centres where continuous covering of the working space (e.g. rear wall, upper roof area) is required.

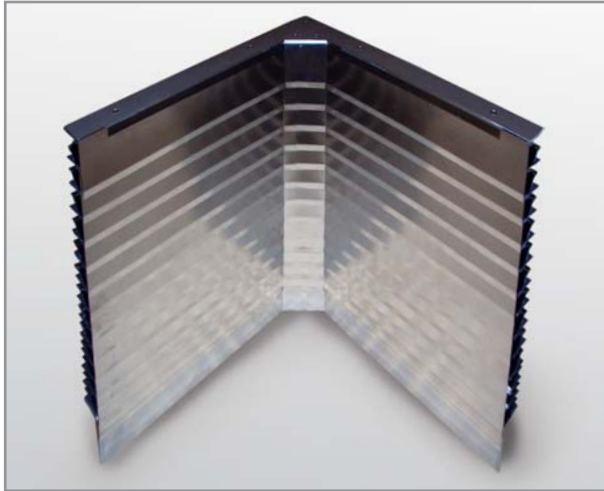

SAMURAI Vector C², interior angle

With its unique design of fixed mounted lamellas only one bellow unit is needed to cover the corner areas. The space allocated to the covering can be used very efficiently, and machining dust is significantly reduced. For swarf protection the VECTOR C² type is equipped with two overlapping, bended metal sheets mounted securely on each fold.

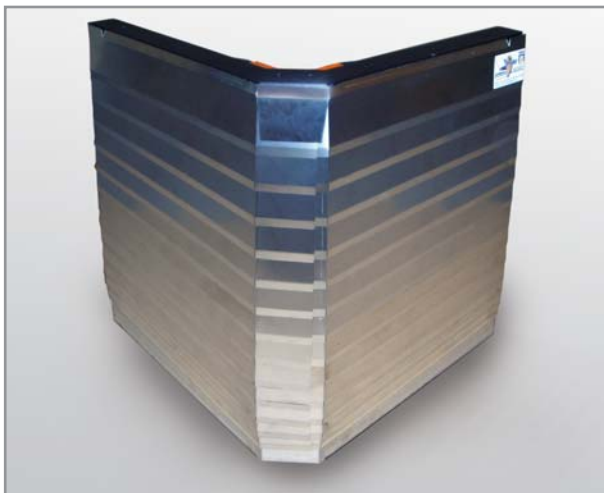

SAMURAI Vector C², exterior angle

The VECTOR C² corner lamella is available as a bended or rounded version providing both a stable structure and reliable functionality.

Even at high operating speeds and accelerations this stable and reliable concept responds flexibly to all interior and exterior angles and combinations of angles.

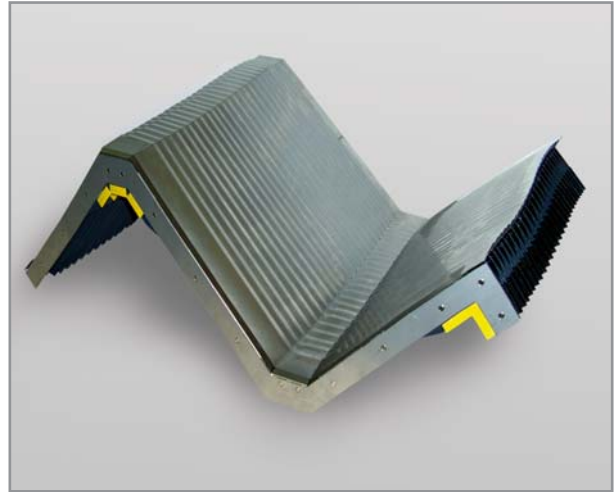

SAMURAI Vector C², combination of interior and exterior angle

The lamellas for this type of SAMURAI Bellows are available in four shapes:

- Outside
- Inside
- Inside round
- Inside Outside

SAMURAI FASTAF TW for limited space

The SAMURAI FASTAF TW has been developed as an alternative to the classic design of protective covers.

This lamella cover »bends around the corner« and is therefore perfectly suited to machines with limited space below the cover.

The compressed cover is turned through 90° allowing more design opportunities. The preload of the lamella's in the area of the radius is maintained through innovative design.



SAMURAI FASTAF TW

SAMURAI BELLOWS

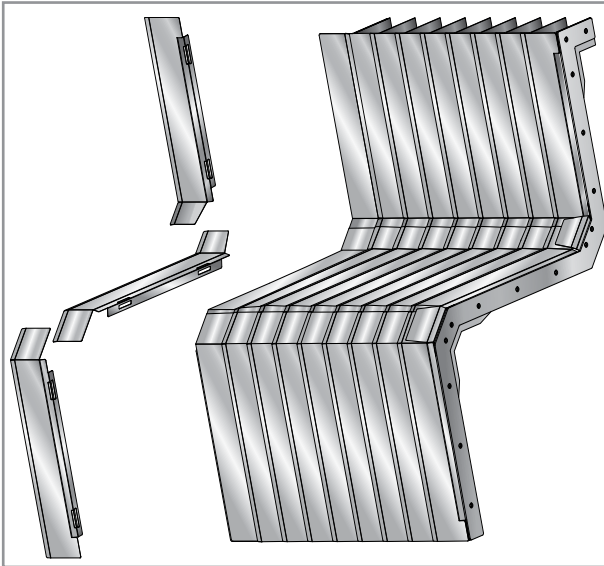

VECTOR C² Inside Outside

Legend	
FB	Width of fold
FZD	Compression per fold
FAZ	Extension per fold
X	Horizontal space required for the lamellas
Y	Vertical space required for the lamellas

FB	FAZ	FZD	X	Y
17,5	20	5	20	40
20	25	5	20	45
25	32	5	25	50
30	40	5	25	65
35	45	5	30	75
40	60	5	35	80
45	65	5	35 - 40	85
50	75	5	45 - 50	95

Vector C²

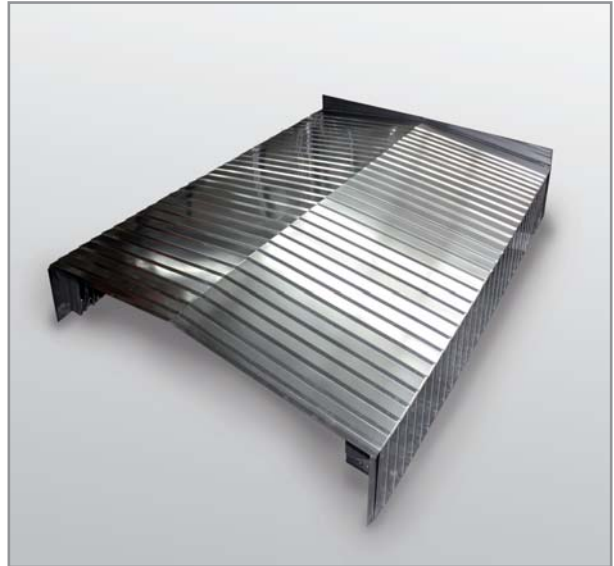

SAMURAI FASTAC, special solution



SAMURAI FASTAF TW for limited space



View into operating machining centre. Result: SAMURAI FASTAF proves reliable even with large chip volumes.

SAMURAI LAMELLA APRONS

02

SERVICE & QUALITY

SAMURAI FASTLAP lamella aprons are a variation of the SAMURAI bellows. They were designed for Z axis covers in machining centres.

The substructure does not consist of ELASTIC bellows but only a carrier material to which the lamellas are fixed.

08

STANDARD BELLOWS

24

SAMURAI BELLOWS

26

SPECIAL BELLOWS

32

BACKWALL SYSTEMS



SAMURAI lamella apron

38

GLADIATOR STEEL COVERS

These cover types are called FASTLAP, and the product line consists of three models. They vary according to how their lamellas are fixed to the carrier material. Special types are available on request.

46

ROLLER SYSTEMS

58

DURASPRING SPIRAL SPRINGS

68

VIEWING SYSTEMS

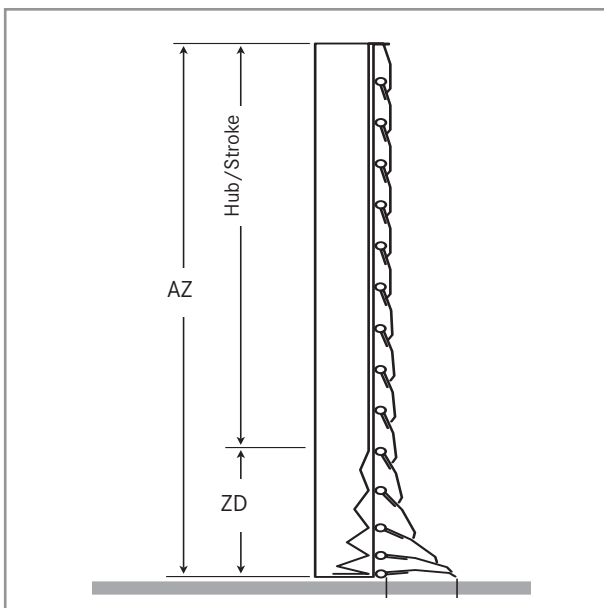

FASTLAP Lamella apron

FASTLAP

The SAMURAI FASTLAP lamella apron is available in two variants:

- lamellas clipped
- lamellas secured with or without preloading

The lamellas are made of stainless steel of 0.5 mm thickness up to a maximum width of 4,000 mm, and mounting is simple. The compression per fold is about 4 mm.

The lamella apron requires a guide on both sides that must allow for a side length of 25 mm.

The lamella apron is secured to a tear-proof Nylon-PU material selected specifically for each application.

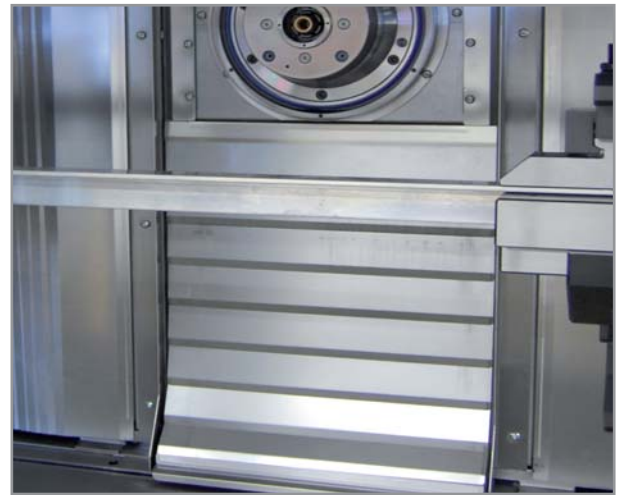

SAMURAI Lamella apron

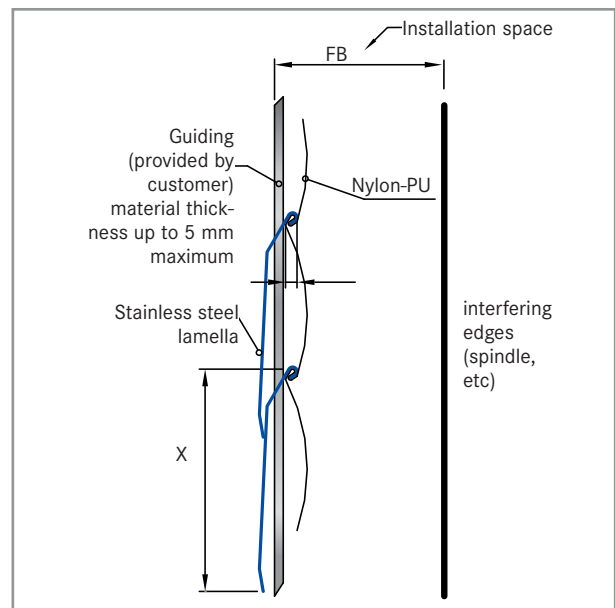

FASTLAP Lamella apron

SAMURAI LAMELLA APRONS

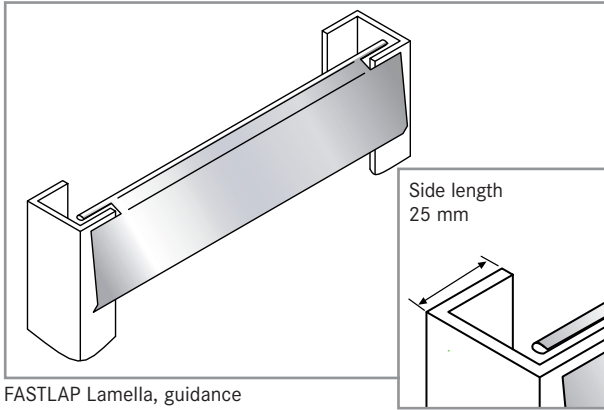

FASTLAP Lamella, guidance

Legende

FB	Width of fold
FZD	Compression per fold
FAZ	Extension per fold
X	Horizontal space required for the lamellas

FB	FAZ	FZD	X
25	38	4	65
30	48	4	75
35	58	4	85
40	68	4	95
45	78	4	105
50	88	4	115

FASTLAP

Special types of lamella aprons

- FASTLAP SA
- FASTLAP SB

FASTLAP SA

The SAMURAI FASTLAP SA lamella apron is also fitted with flexible mounted lamellas. These hinged without preloading. The lamellas are made of stainless steel 0.5 mm thick up to a maximum length of 4,000 mm. Within these dimensions the length of lamellas and width of folds can be individually chosen. For compression 4 mm per fold must be considered.

The FASTLAP SA type exhibits a greater lateral stability, especially for widths in excess of 1,000 mm, when compared with the standard FASTLAP type.

Therefore this type is suitable for higher travelling speeds. The higher surface pressure also effectively prevents the lamellas from »lifting off«. At the machine there must be guides on both sides of the lamella apron over a side length of 25 mm; the thickness can be up to 5 mm.

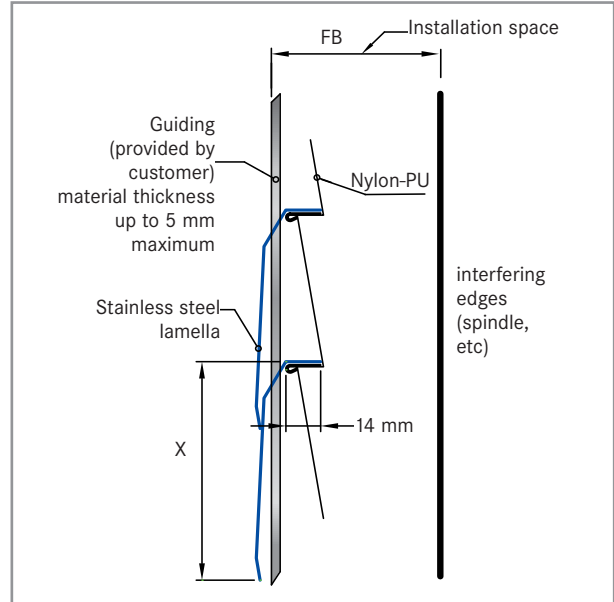

Lamella apron FASTLAP SA

FASTLAP SB

Compared with FASTLAP SA this type exhibits a higher lateral stability, which becomes particularly necessary on widths greater than 1000 mm. At the machine there must be guides on both sides of the lamella apron over a side length of 25 mm. Unlike FASTLAP and the FASTLAP SA types for the FASTLAP SB apron the thickness of the guides can be up to 6 mm. The vertical lamella overlap requires an additional space of 15 mm. Owing to this design the lamellas cannot be lifted. The lamella apron is secured to a tear-proof Nylon-PU material selected specifically for each application.

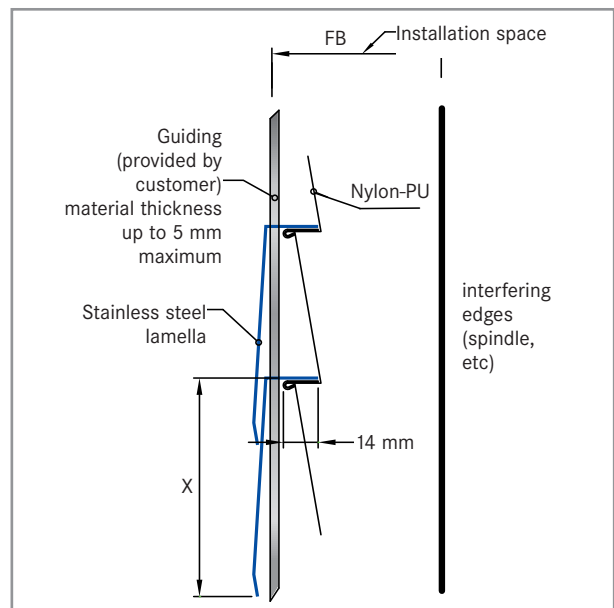

Lamella apron FASTLAP SB