

COVERS FOR MOVING COLUMN MACHINES

These machines with their large travel and working space areas require a special solution. For the workspace area, both backwall systems and large bellows with or without lamellas are suitable.

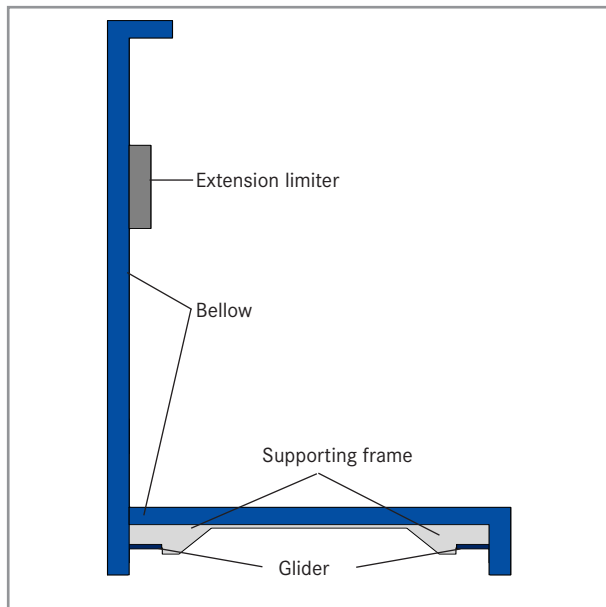

Typical backwall cover

Depending on the machine type and its concept two design principles are applicable:

- Column type cover
- Venetian blind type

Column type cover

This design principle is used if a guiding rail is not possible. The column milling cover type is L-shaped and runs on gliders.

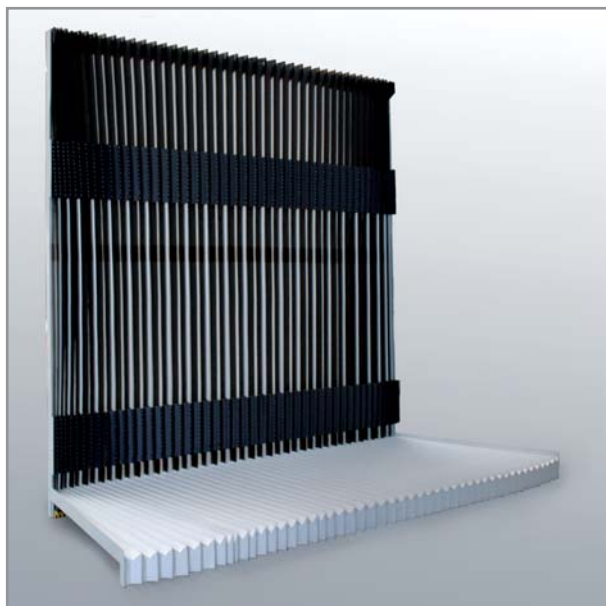

Cover for column miller used for medical applications

Venetian blind type

If a guiding frame is available, the bellow can be supported using profiles, roller or rail systems.

The guiding system has been successfully tested on a high speed test machine at the PTW under worst conditions. Over one million cycles were recorded.



Venetian blind type cover with SAMURAI Bellows for moving column machine

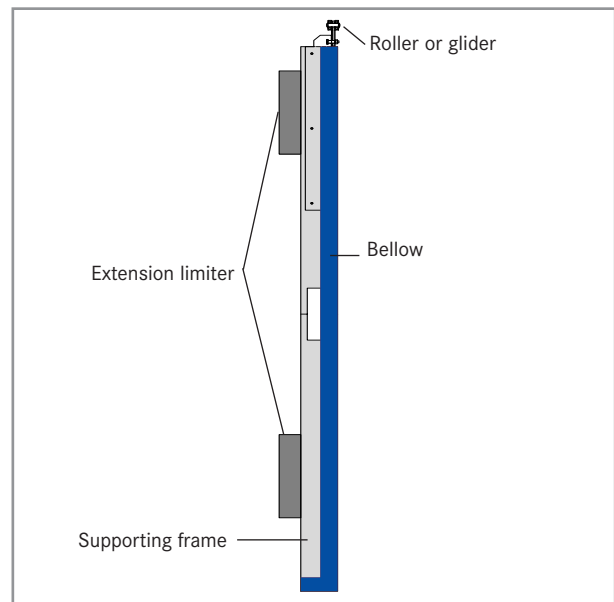

Design of venetian blind cover

CUBE BACKWALL SYSTEMS

Milling machine centres are fitted with complete backwall systems.

The design of an individual solution is time and cost intensive, and these can be reduced only if larger piece numbers are produced.

A modular built-up rear wall system can reduce the engineering efforts even for a single backwall - and the CUBE Backwall system was developed.

- Suitable for protection systems for two axes
- Significant reduction of engineering time
- Fast and detailed information for machine engineering
- The costs for each CUBE rear wall system are well below the costs of an individually designed concept



CUBE Backwall system

These features benefit machine builders with smaller production numbers and special machines.

The great savings in time and money compared with previous construction requests and orders could otherwise only be managed with large production numbers of identical design.

Design

Using the straightforward formulas we can determine the width and the height of the outside frame of the cover and for the sheet metal design and then provide these for the machine construction. The covers in the CUBE model consist of bellows which are incorporated along the X and Y axis fitted individually for the perfect match. Depending on the loads and machine travel speeds we select suitable bellow guiding:

- CUBE 60: standard profiled glider guide for speeds up to 60 m/min
- CUBE 80: Backwall system with rail glider guide for speeds up to 80 m/min
- CUBE 80+: High load roller rail guide for speeds over 80 m/min
- CUBE X: Customized solutions

For backwall protection SAMURAI Bellows are used. Fixed mounted stainless steel lamellas protect the bellows against hot and sharp edged swarf.



Through spindle

The spindle opening is designed to the customer's requirements.

The frame construction is made of solid warp resistant steel sheet. The mounting options for the rear wall can be integrated in the frame construction, but the force transmission along the X axis requires connections to the machine in the upper and lower areas.

For an optimum load transmission to the X axis cover protection, this cover must be connected at the top and bottom with the moving column or other supporting machine parts.

Versions of CUBE X with large extensions up to five meters long and three meters high have already been realized.

Additional concepts such as DynaSynchro or pantographs can absorb the dynamic loads. Therefore a travelling speed up to 120 m/min can be realized.



SERVICE & QUALITY 02

STANDARD BELLOWS 08

SAMURAI BELLOWS 18

SPECIAL BELLOWS 26

BACKWALL SYSTEMS 33

GLADIATOR STEEL COVERS 38

ROLLER SYSTEMS 46

DURASPRING SPIRAL SPRINGS 58

VIEWING SYSTEMS 68

CUBE BACKWALL SYSTEMS

02	SERVICE & QUALITY
08	STANDARD BELLOWS
18	SAUMRAI BELLOWS
26	SPECIAL BELLOWS
34	BACKWALL SYSTEMS
38	GLADIATOR STEEL COVERS
46	ROLLER SYSTEMS
58	DURASPRING SPIRAL SPRINGS
68	VIEWING SYSTEMS



CUBE

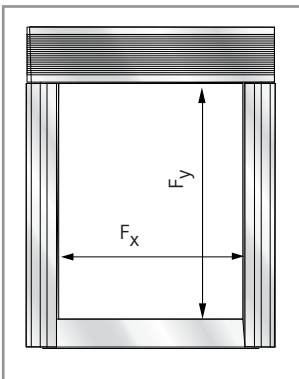

Calculation of spindle opening

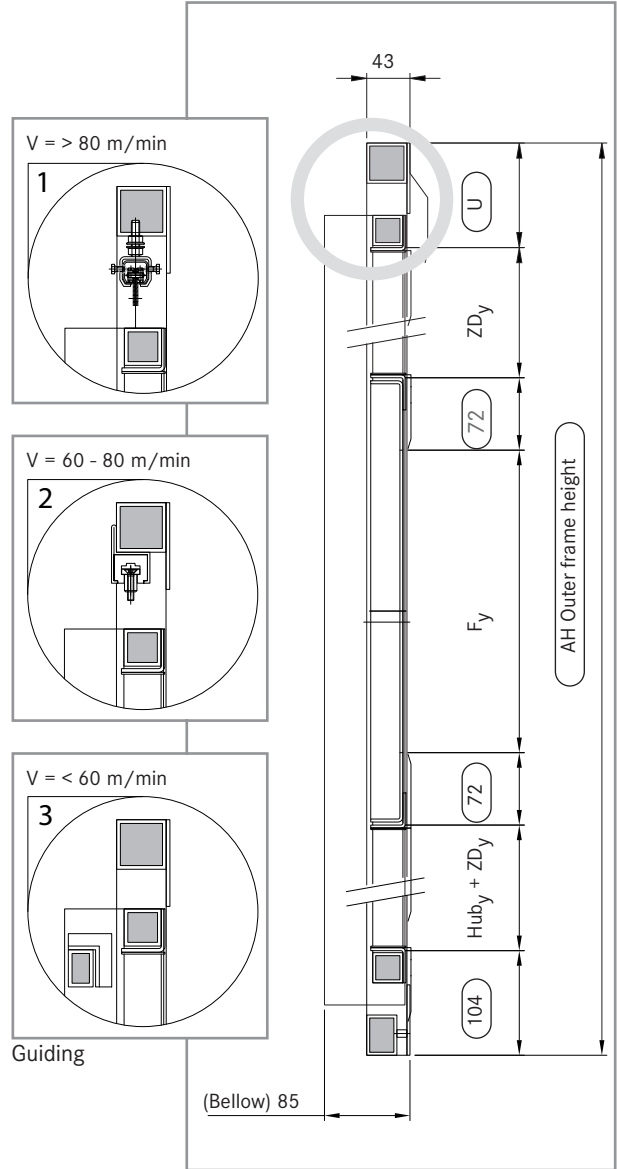

Calculation of outer frame height

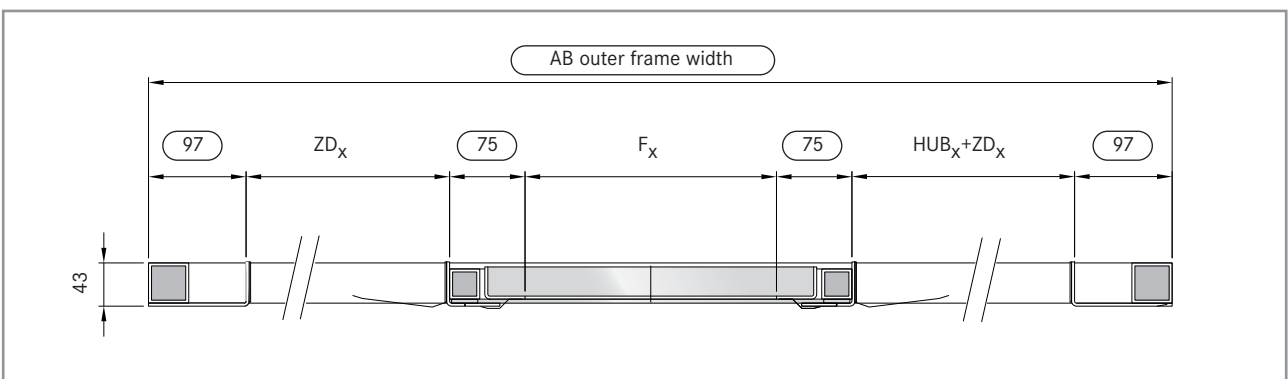

Calculation of outer frame width

CUBE BACKWALL SYSTEMS

CUBE	Guiding (V m/min)	Application area
CUBE 60	Standard glider guiding	up to 60 m/min
CUBE 80	Rail glider guiding	up to 80 m/min
CUBE 80+	Roller glide guiding	up to 80 m/min
CUBE X	customized	customized

Design	
Data to be provided by customer	
V_x	Travel speed in X direction
V_y	Travel speed in Y direction
Hub_x	Required working area travel in X direction
Hub_y	Required working area travel in Y direction
F_x	Width of opening for spindle lead-through
F_y	Height of opening for spindle
ZD_x	Required compression length X axis
ZD_y	Required compression length Y axis
AB	Frame width CUBE
AH	Frame height CUBE
U	Fixed dimensions upper bar
	HEMA specification values

Factors of compression	
CUBE 60	
ZD Faktor _{60x}	0.12
U_{60}	104 mm
CUBE 80	
ZD Faktor _{80x}	0.155
U_{80}	137 mm
CUBE 80+	
ZD Faktor ₈₀₊	0.165
U_{80+}	137 mm
Allgemeinfaktor Y-Achse	
ZDFaktor _y	0.075

Basic principle for calculation

These data also cover extreme situations. If less space is available in the customer's machine construction, the data are adapted accordingly.

Calculation example
Example calculation for CUBE 80+
V_x 80 m/min
V_y 80 m/min
Hub_x 800 mm
Hub_y 650 mm
F_x 200 mm
F_y 200 mm
Calculation of the compression
$ZD_x = Hub_x \times ZDFactor_{80+} = 800 \text{ mm} \times 0.165 = [132 \text{ mm}]$
$ZD_y = Hub_y \times ZDF_y = 650 \text{ mm} \times 0.075 = [49 \text{ mm}]$
[] = values rounded up without decimal place
Calculation the results for CUBE₈₀₊
Outside frame width in X direction:
$AB = (\text{System spec. value}^*) + Hub_x + F_x + 2 \times ZD_x$
$AB = (97 + 75 + 75 + 97) + 800 + 200 + 2 \times 132 = 1.608 \text{ mm}$
Outside frame height in Y direction
$AH = (\text{System spec. value}^*) + U_{80+} + Hub_y + F_y + 2 \times ZD_y$
$AH = (104 + 72 + 72) + 137 + 650 + 200 + 2 \times 49 = 1.333 \text{ mm}$
*HEMA system specification values

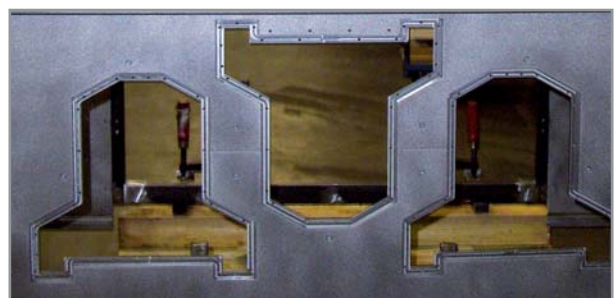

Types of spindle openings

SERVICE & QUALITY	02
STANDARD BELLOWS	08
SAUWRAI BELLOWS	18
SPECIAL BELLOWS	26
BACKWALL SYSTEMS	35
GLADIATOR STEEL COVERS	38
ROLLER SYSTEMS	46
DURASPRING SPIRAL SPRINGS	58
VIEWING SYSTEMS	68

PROJECT TEAM

The design and realisation of large protection systems and complete backwall systems is supervised by an experienced team during all stages of manufacture.

Engineering and design

All important details of the machine for the design of new protection systems are integrated in the engineering stages. Every cover is individually designed to meet the specific requirements and to fit perfectly for each machine tool.

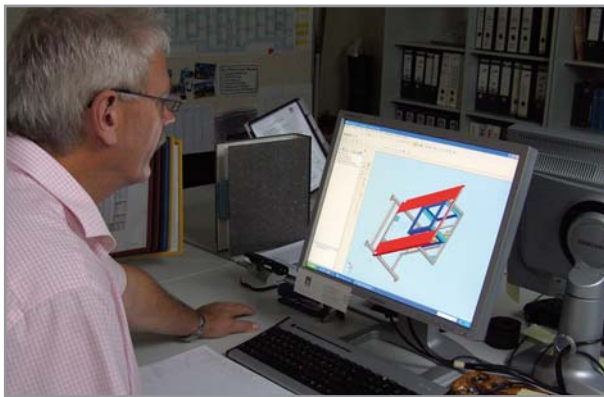

Design of new protection systems

Production of components

All components are produced with modern machines. Sheet metal components are accurately cut to fit by laser. Other parts of the covers, such as pantographs or gliders for smooth running, are chosen individually depending on the area of application and travelling speed.

During each production step all parts and materials are regularly checked for accurate dimensions and proper functioning. Visible surfaces are polished to a special finish.

Test set up

Before shipping all parts are checked for accurate visual appearance and perfect functionality.



Functional test for prototyping



Roof cover with a length of more than nine meters, and a self-supporting width of more than five meters



Backwall system for XY-axis

Shipment

To be as cost efficient as possible all parts are shipped in compact and protective packaging. Customers' internal processes are given special consideration.



Compact returnable shipping unit for backwall systems (optional)

CUBE BACKWALL SYSTEMS



SERVICE & QUALITY	02
STANDARD BELLOWS	08
SAUWRAI BELLOWS	18
SPECIAL BELLOWS	26
BACKWALL SYSTEMS	37
GLADIATOR STEEL COVERS	38
ROLLER SYSTEMS	46
DURASPRING SPIRAL SPRINGS	58
VIEWING SYSTEMS	68